

VPT15-2800S Series

HIGH RELIABILITY COTS DC-DC CONVERTERS

DESCRIPTION

The VPT15 series of isolated COTS DC-DC converters is a cost effective solution for many demanding high reliability applications. A wide input voltage range accommodates nominal 28V inputs including avionics, mobile, ground systems, and other applications. Low input and output ripple, fixed operating frequency, and companion EMI filters simplify system design and compliance. A proven design heritage, no optoisolators and a rugged all metal or optional epoxy encapsulated package ensure long term reliability.

The VPT15 series is intended for harsh environments including severe vibration, shock and temperature cycling. Testing is to JESD22, MIL-STD-810, and MIL-STD-883.

These converters are designed and manufactured in a facility certified to ISO9001, J-STD-001 and IPC-A-610.

This product may incorporate one or more of the following U.S. patents:

5,784,266
5,790,389
5,963,438
5,999,433
6,005,780
6,084,792
6,118,673

FEATURES

- High Reliability at Low Cost
- Up to 15 Watts Maximum Output Power
- Wide Input Voltage Range: 15 to 50 Volts per MIL-STD-704 and MIL-STD-1275
- High Input Transient Voltage: 80 Volts for 1 sec per MIL-STD-704A
- Input Undervoltage Lockout
- Fixed Frequency
- Output Voltage Trim (+10% / -20%)
- Output Soft Start
- Current Limit Protection
- Short Circuit Protection
- Magnetic Feedback, no Optoisolators
- Wide Temperature Range, -55°C to 100°C
- Internally Conformal Coated
- Standard Six Sided Non-Hermetic Rugged Metal Package
- Optional Six Sided Rugged Epoxy Encapsulated Package with Integral Metalized EMI shield that is fully compatible with aqueous cleaning processes
- Meets MIL-STD-461 Revisions C, D, E and F EMC Requirements When Used With VPT's EMI Filters



Figure 1 – VPT15-2800S DC–DC Converter Standard Metal Package



Figure 2 VPT15-2800SW DC–DC Converter Optional Epoxy Encapsulated Package

(Not to Scale)

SPECIFICATIONS (T_{CASE} = -55°C to +100°C, V_{IN} = +28V ± 5%, Full Load, Unless Otherwise Specified)

ABSOLUTE MAXIMUM RATINGS

Input Voltage (Continuous)	50 V _{DC}	Junction Temperature Rise to Case	+15°C
Input Voltage (Transient, 1 second)	80 Volts	Storage Temperature	-55°C to +125°C
Output Power ¹	15 Watts	Lead Solder Temperature (10 seconds)	300°C
Power Dissipation (Full Load, T _{CASE} = +100°C)	6 Watts	Weight (Maximum)	32 Grams

Parameter	Conditions	VPT15-283R3S			VPT15-2805S			Units
		Min	Typ	Max	Min	Typ	Max	
STATIC								
INPUT Voltage ⁴	Continuous	15	28	50	15	28	50	V
	Transient, 1 sec	-	-	80	-	-	80	V
Current	Inhibited	-	4	6	-	4	6	mA
	No Load	-	50	65	-	50	65	mA
Ripple Current	Full Load, 20Hz to 10MHz	-	40	75	-	50	80	mA _{p-p}
Inhibit Pin Input ⁴		0	-	1.5	0	-	1.5	V
Inhibit Pin Open Circuit Voltage ⁴		9.0	11.0	13.0	9.0	11.0	13.0	V
UVLO Turn On		12.0	-	14.8	12.0	-	14.8	V
UVLO Turn Off ⁴		11.0	-	14.5	11.0	-	14.5	V
OUTPUT Voltage	V _{OUT} T _{CASE} = 25°C	3.25	3.30	3.35	4.92	5.00	5.08	V
	V _{OUT} T _{CASE} = -55°C to +100°C	3.21	3.30	3.38	4.87	5.00	5.13	V
Power ³		0	-	10	0	-	15	W
Current ³	V _{OUT}	0	-	3.0	0	-	3.0	A
Ripple Voltage	V _{OUT} Full Load, 20Hz to 10MHz	-	10	40	-	10	40	mV _{p-p}
Line Regulation	V _{OUT} V _{IN} = 15V to 50V	-	1	10	-	1	10	mV
Load Regulation	V _{OUT} No Load to Full Load	-	1	10	-	1	10	mV
EFFICIENCY		67	70	-	72	76	-	%
LOAD FAULT POWER DISSIPATION	Overload ⁴	-	-	8	-	-	9	W
	Short Circuit	-	-	8	-	-	8	W
CAPACITIVE LOAD ⁴		-	-	1000	-	-	1000	μF
SWITCHING FREQUENCY		400	500	550	400	500	550	kHz
ISOLATION	500 V _{DC}	100	-	-	100	-	-	MΩ
MTBF (MIL-HDBK-217F)	GM @ T _c = 55°C	-	445	-	-	445	-	kHrs
DYNAMIC								
Load Step Output Transient	V _{OUT} Half Load to Full Load	-	170	250	-	170	250	mV _{PK}
Load Step Recovery ²		-	300	450	-	300	450	μSec
Line Step Output Transient ⁴	V _{OUT} V _{IN} = 16V to 40V	-	350	550	-	350	550	mV _{PK}
Line Step Recovery ^{2, 4}		-	400	550	-	400	550	μSec
Turn On Delay	V _{OUT} V _{IN} = 0V to 28V	-	10	20	-	10	20	mSec
Turn On Overshoot		-	0	15	-	0	25	mV _{PK}

- Notes:
1. Dependent on output voltage.
 2. Time for output voltage to settle within 1% of its nominal value.
 3. Derate linearly to 0 at 110°C.
 4. Verified by qualification testing.

SPECIFICATIONS (T_{CASE} = -55°C to +100°C, V_{IN} = +28V ± 5%, Full Load, Unless Otherwise Specified)

ABSOLUTE MAXIMUM RATINGS

Input Voltage (Continuous)	50 V _{DC}	Junction Temperature Rise to Case	+15°C
Input Voltage (Transient, 1 second)	80 Volts	Storage Temperature	-55°C to +125°C
Output Power ¹	15 Watts	Lead Solder Temperature (10 seconds)	300°C
Power Dissipation (Full Load, T _{CASE} = +100°C)	6 Watts	Weight (Maximum)	32 Grams

Parameter	Conditions	VPT15-2812S			VPT15-2815S			Units
		Min	Typ	Max	Min	Typ	Max	
STATIC								
INPUT Voltage ⁴	Continuous	15	28	50	15	28	50	V
	Transient, 1 sec	-	-	80	-	-	80	V
Current	Inhibited	-	4	6	-	4	6	mA
	No Load	-	50	65	-	50	65	mA
Ripple Current	Full Load, 20Hz to 10MHz	-	40	80	-	40	80	mA _{p-p}
Inhibit Pin Input ⁴		0	-	1.5	0	-	1.5	V
Inhibit Pin Open Circuit Voltage ⁴		9.0	11.0	13.0	9.0	11.0	13.0	V
UVLO Turn On		12.0	-	14.8	12.0	-	14.8	V
UVLO Turn Off ⁴		11.0	-	14.5	11.0	-	14.5	V
OUTPUT Voltage	V _{OUT} T _{CASE} = 25°C	11.82	12.0	12.18	14.77	15.0	15.23	V
	V _{OUT} T _{CASE} = -55°C to +100°C	11.70	12.0	12.30	14.62	15.0	15.38	V
Power ³		0	-	15	0	-	15	W
Current ³	V _{OUT}	0	-	1.25	0	-	1.0	A
Ripple Voltage	V _{OUT} Full Load, 20Hz to 10MHz	-	10	30	-	10	30	mV _{p-p}
Line Regulation	V _{OUT} V _{IN} = 15V to 50V	-	1	10	-	1	10	mV
Load Regulation	V _{OUT} No Load to Full Load	-	1	10	-	1	10	mV
EFFICIENCY		76	80	-	76	80	-	%
LOAD FAULT POWER DISSIPATION	Overload ⁴	-	-	8	-	-	8	W
	Short Circuit	-	-	8	-	-	8	W
CAPACITIVE LOAD ⁴		-	-	500	-	-	500	μF
SWITCHING FREQUENCY		400	500	550	400	500	550	kHz
ISOLATION	500 V _{DC}	100	-	-	100	-	-	MΩ
MTBF (MIL-HDBK-217F)	GM @ T _C = 55°C	-	445	-	-	445	-	kHrs
DYNAMIC								
Load Step Output Transient	V _{OUT} Half Load to Full Load	-	250	350	-	250	350	mV _{PK}
Load Step Recovery ²		-	150	250	-	150	250	μSec
Line Step Output Transient ⁴	V _{OUT} V _{IN} = 16V to 40V	-	450	700	-	450	700	mV _{PK}
Line Step Recovery ^{2, 4}		-	400	550	-	400	550	μSec
Turn On Delay	V _{OUT} V _{IN} = 0V to 28V	-	10	20	-	10	20	mSec
Turn On Overshoot		-	0	50	-	0	50	mV _{PK}

- Notes:
1. Dependent on output voltage.
 2. Time for output voltage to settle within 1% of its nominal value.
 3. Derate linearly to 0 at 110°C.
 4. Verified by qualification testing.

BLOCK DIAGRAM

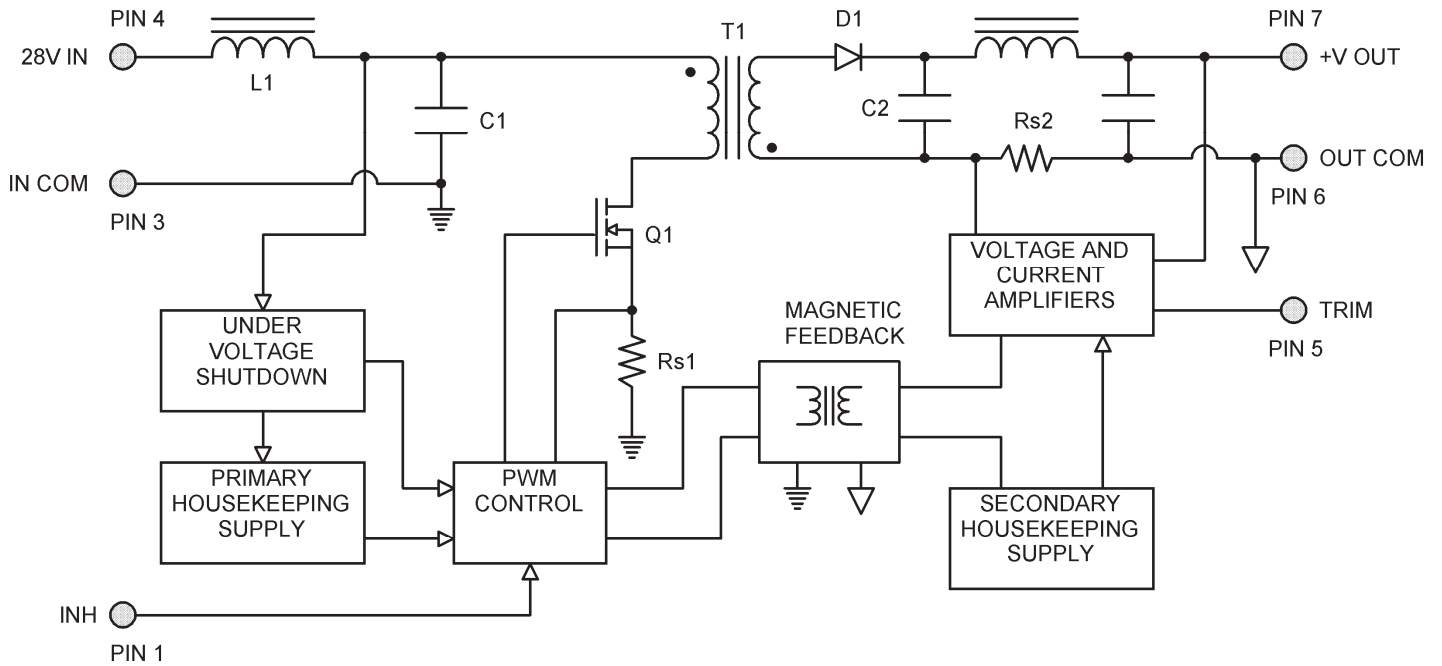

Figure 3

CONNECTION DIAGRAM

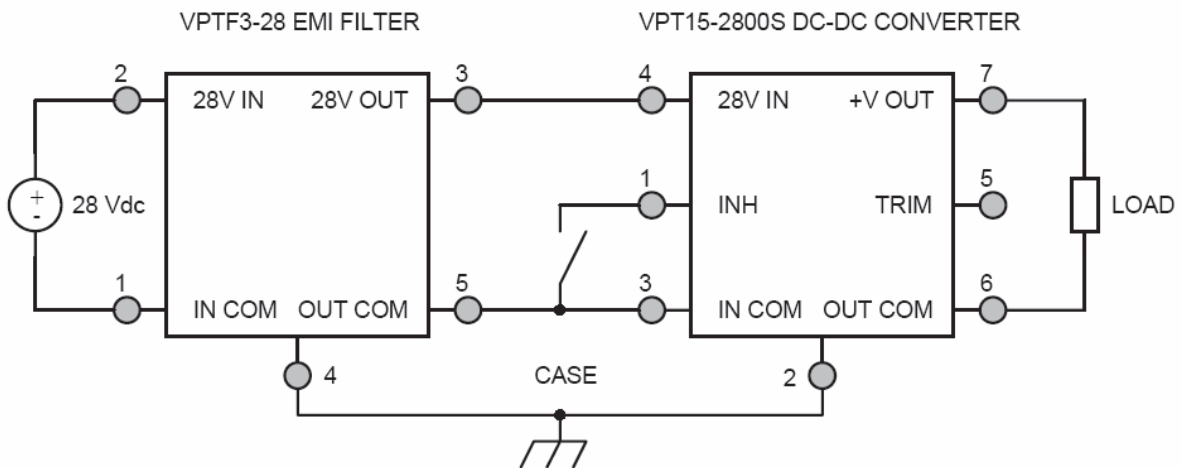

Figure 4
(Shown with optional EMI filter)

CONNECTION DIAGRAMS

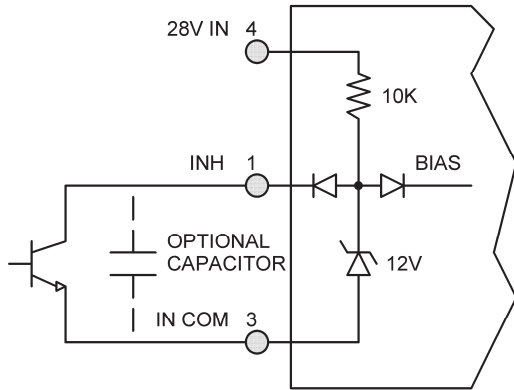

Figure 5 –Inhibit Circuit

(Shown with optional capacitor for turn-on delay)

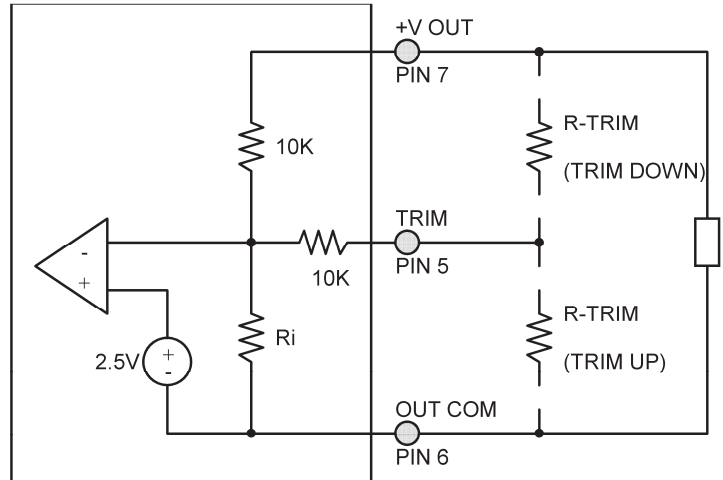

Figure 6 – Output Voltage Trim Circuit

OUTPUT VOLTAGE TRIM

The output voltage can be trimmed down by connecting a resistor between the TRIM pin and the +V OUT pin, or can be trimmed up by connecting a resistor between the TRIM pin and the OUT COM pin as shown in Figure 5. The maximum trim range is +10% up and –20% down. The appropriate resistor values versus the output voltage are given in the trim table below.

VPT15-283R3S		VPT15-2805S		VPT15-2812S		VPT15-2815S	
+V _{OUT} (V)	R _{TRIM} (Ω)	+V _{OUT} (V)	R _{TRIM} (Ω)	+V _{OUT} (V)	R _{TRIM} (Ω)	+V _{OUT} (V)	R _{TRIM} (Ω)
3.60	7.27k	5.5	39.6k	13.2	10.7k	16.50	6.5k
3.55	89.2k	5.4	52k	13.0	14.8k	16.25	9.8k
3.50	114k	5.3	72.6k	12.8	21k	16.00	14.8k
3.45	155k	5.2	113.9k	12.6	31.3k	15.75	23k
3.40	238k	5.1	237k	12.4	51.9k	15.50	39.6k
3.35	487k	5.0	--	12.2	114k	15.25	89k
3.30	--	4.9	232.5k	12.0	--	15.00	--
3.25	144k	4.8	106.1k	11.8	457k	14.75	482k
3.20	61.9k	4.7	64k	11.6	218k	14.50	231k
3.15	34.7k	4.6	43k	11.4	139k	14.25	147k
3.10	21k	4.5	30.4k	11.2	99k	14.00	105k
3.05	12.79k	4.4	22k	11.0	75.2k	13.75	80.2k
3.00	7.33k	4.3	16k	10.8	59.4k	13.50	63.5k
		4.2	11.5k	10.6	48k	13.25	51.6k
		4.1	8.0k	10.4	39.5k	13.00	42.6k
		4.0	5.2k	10.2	32.9k	12.75	35.6k
				10.0	27.6k	12.50	30k
				9.8	23.3k	12.25	25.5k
				9.6	19.7k	12.00	21.7k

EFFICIENCY PERFORMANCE CURVES ($T_{CASE} = 25^{\circ}C$, Full Load, Unless Otherwise Specified)

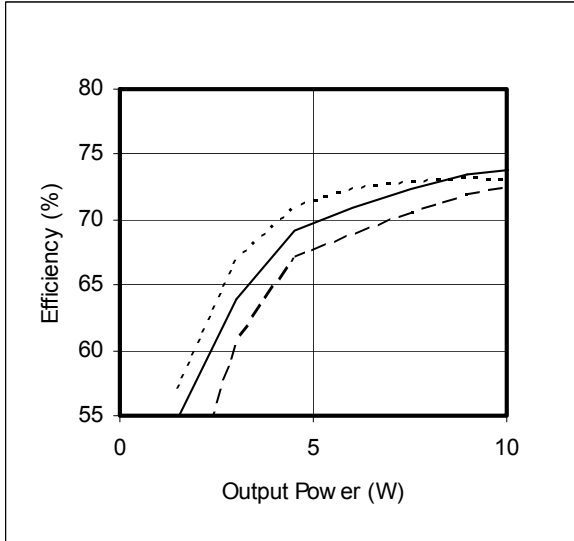

Figure 7 – VPT15-283R3S
Efficiency (%) vs. Output Power (W)

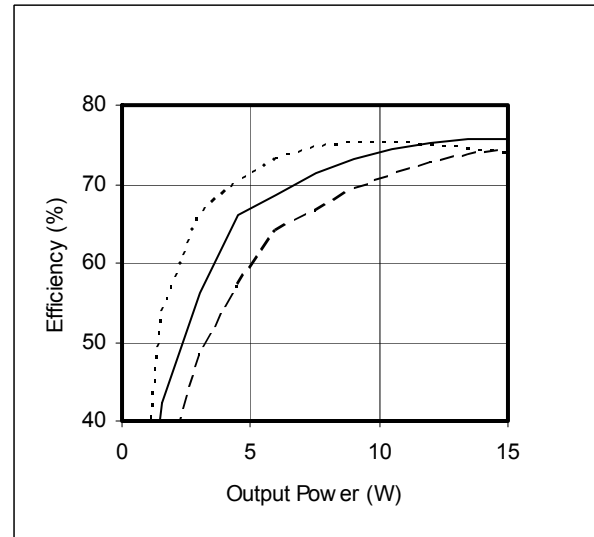

Figure 8 – VPT15-2805S
Efficiency (%) vs. Output Power (W)

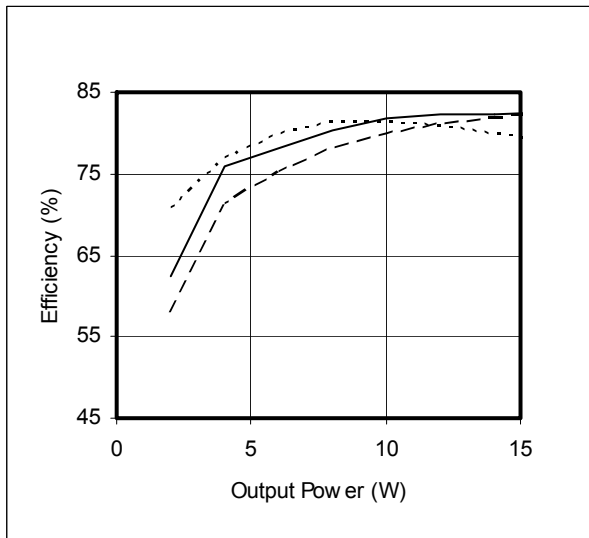

Figure 9 – VPT15-2812S
Efficiency (%) vs. Output Power (W)

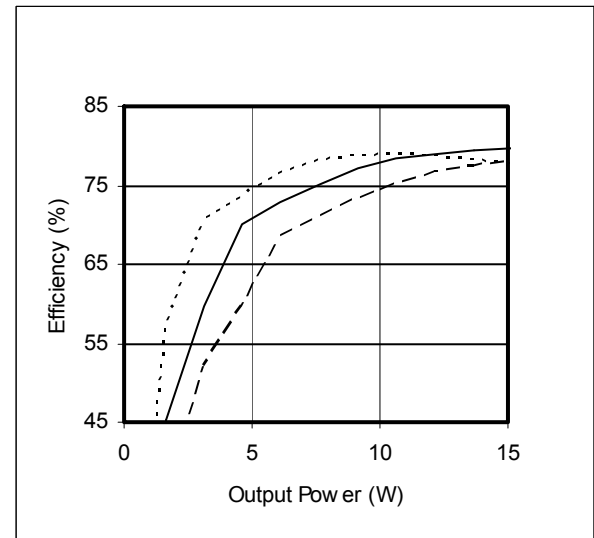

Figure 10 – VPT15-2815S
Efficiency (%) vs. Output Power (W)

EMI PERFORMANCE CURVES

($T_{CASE} = 25^{\circ}C$, $V_{IN} = +28V \pm 5\%$, Full Load, Unless Otherwise Specified)

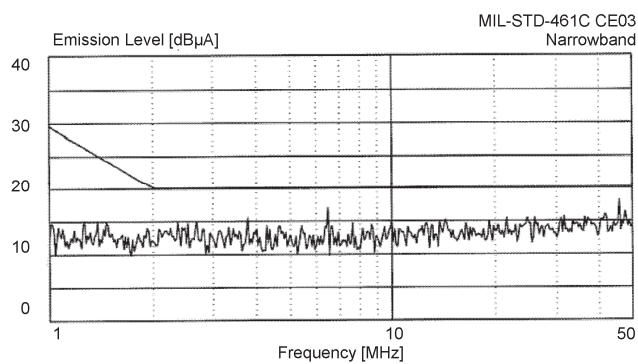
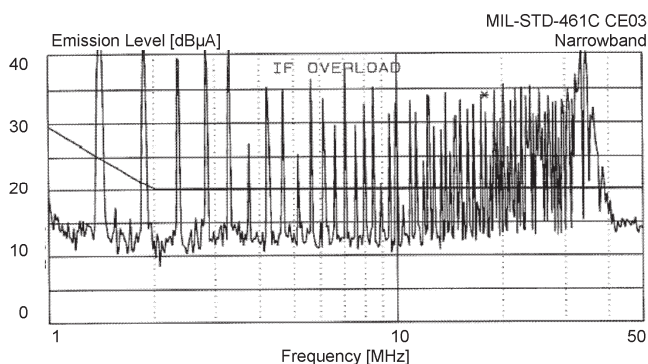
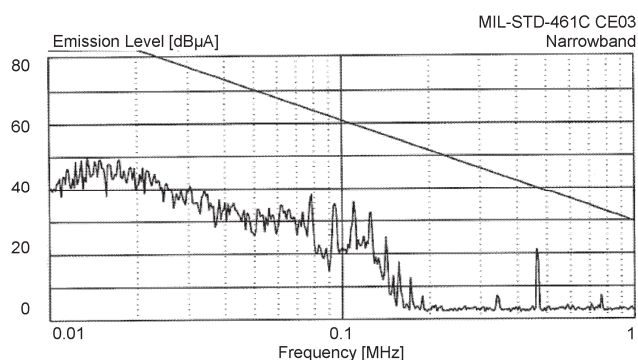
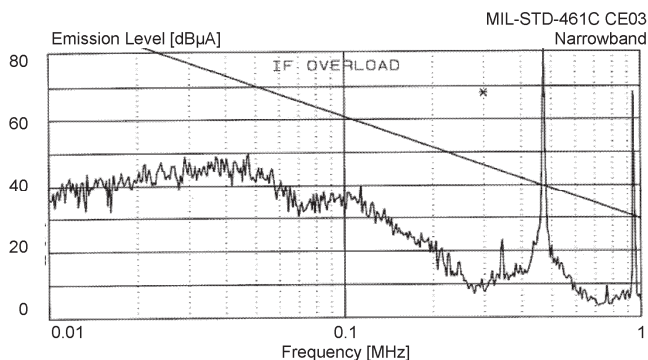

Figure 11 – VPT15-2800S without EMI Filter

Figure 12 – VPT15-2800S with VPTF Series EMI Filter

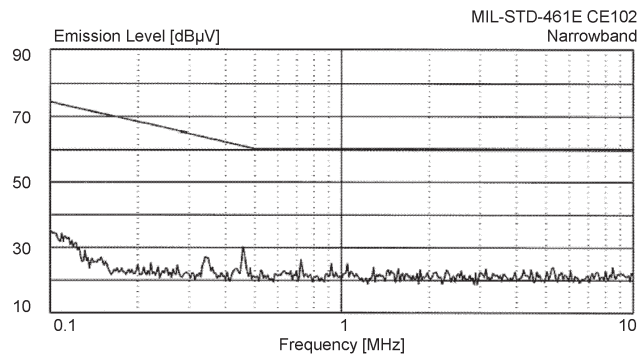
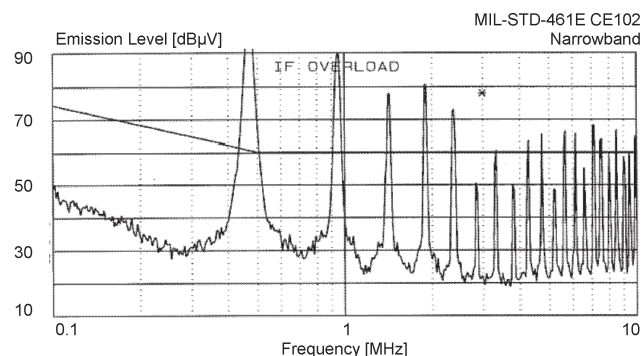
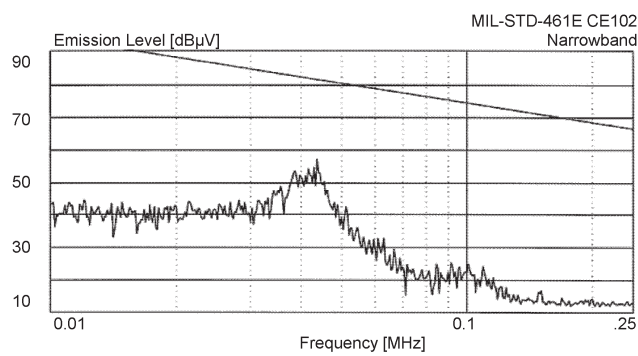
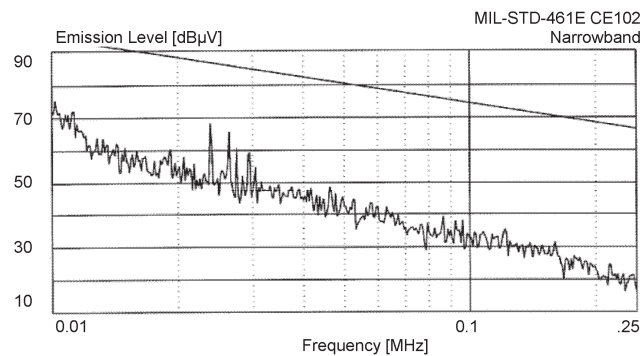
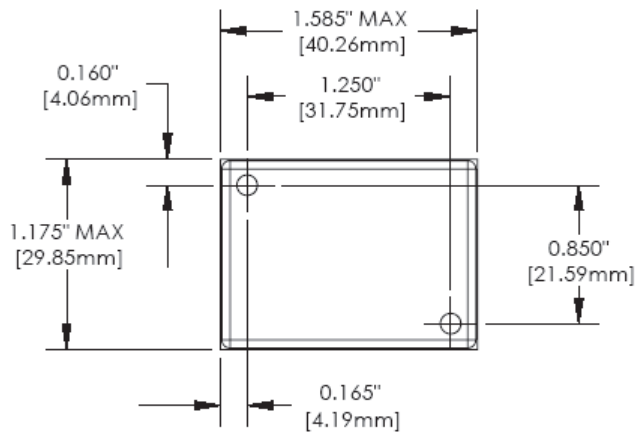

Figure 13 – VPT15-2800S without VPTF Series EMI Filter

Figure 14 – VPT15-2800S with VPTF Series EMI Filter

STANDARD METAL PACKAGE



TOP VIEW

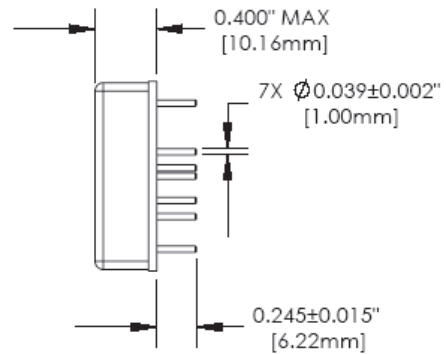

SIDE VIEW

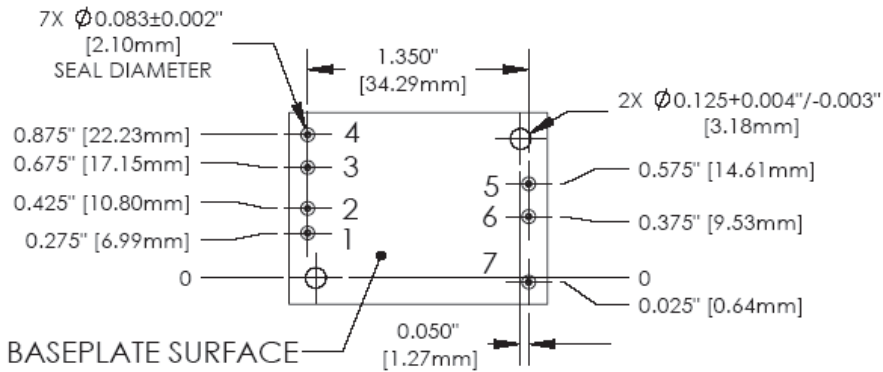

BOTTOM VIEW

Pin	Function
1	INHIBIT
2	CASE
3	IN COM
4	28VIN
5	TRIM
6	OUTCOM
7	+VOUT

Figure 15 – Package and Pinout
(Dimensional Limits are ± 0.005 " Unless Otherwise Stated)

Package Notes

- Case temperature is measured on the center of the baseplate surface.
- Materials: Baseplate – aluminum, conductive conversion coating.
Cover – nickel plated.
Pins - copper, gold over nickel plating.
- Mounting holes are not threaded. Recommended fastener is 4-40.
- This Package is not hermetic. VPT offers a wide range of hermetic products. Please contact VPT for details if hermetic products are required.

OPTIONAL EPOXY ENCAPSULATED PACKAGE

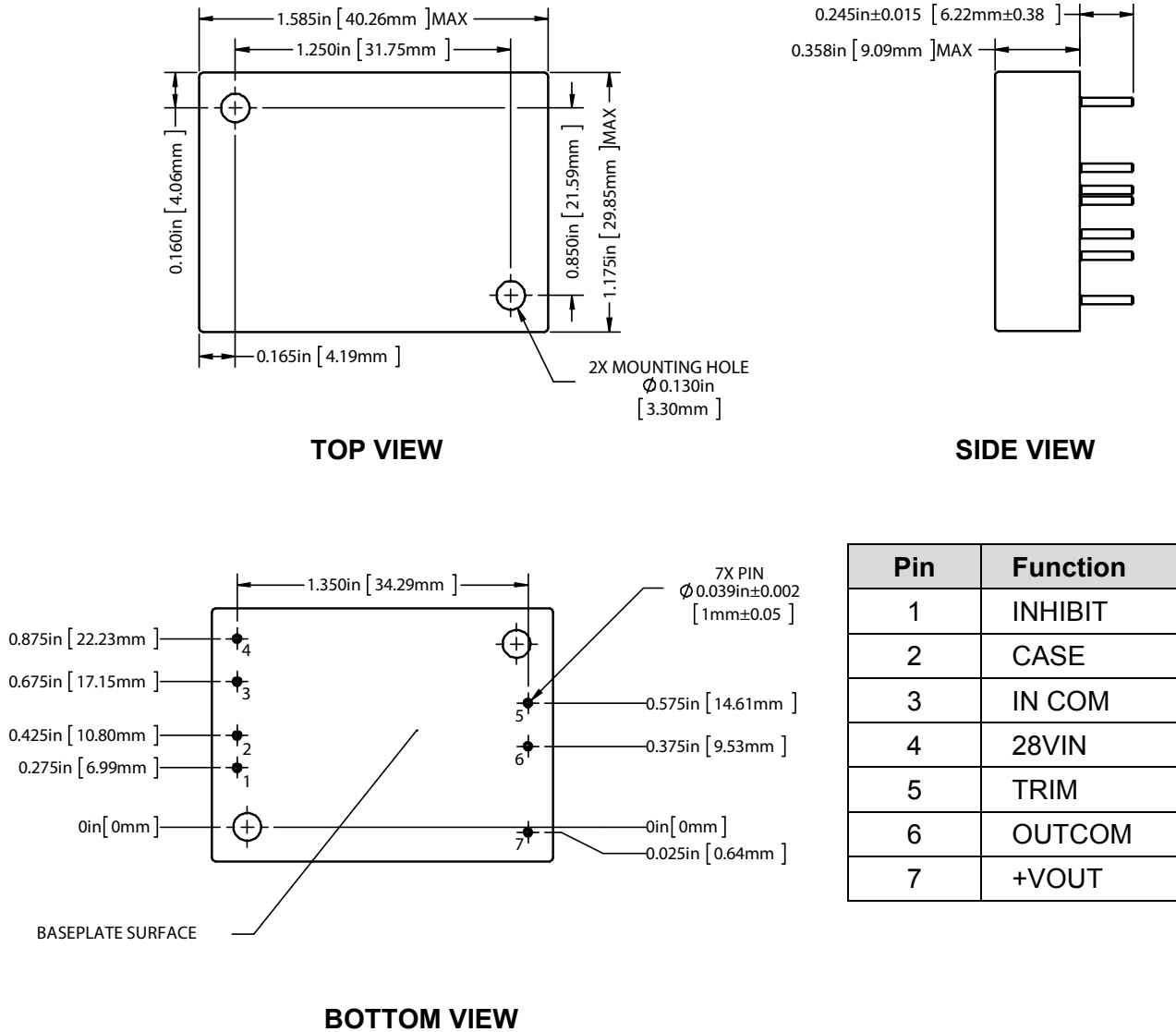

Figure 16 – Package and Pinout
(Dimensional Limits are ± 0.005 " Unless Otherwise Stated)

Package Notes

- Case temperature is measured on the center of the baseplate surface.
- Materials: Body - epoxy with integral metalized EMI shield.
Pins - copper, gold over nickel plating.
- Mounting holes are not threaded. Recommended fastener is 4-40.
- This package is highly resistant to chemical, solvent and salt environments and is fully compatible with high volume manufacturing processes including wave solder, cleaning solvents, high pressure sprays and aqueous wash processes.

PACKAGE PIN DESCRIPTION

Pin	Function	Description
1	INHIBIT	This is an open collector input. Logic Low = Disabled Output. Connect the inhibit pin to input common to disable the output. Unconnected, open collector or open drain = Enabled Output.
2	CASE	Case Connection.
3	INCOM	Input Return Connection.
4	28VIN	Positive Input Voltage Connection.
5	TRIM	Trim Output Voltage to +10%, -20% of Nominal Value. Leave open if not used.
6	OUTCOM	Output Return Connection.
7	+VOUT	Positive Output Voltage Connection.

100% ENVIRONMENTAL SCREENING

Screening	Condition
Internal Visual	IPC-A-610, Class 3
Stabilization Bake	MIL-STD-883, Method 1008, Condition B, 125°C, 24 hours
Temperature Cycling	MIL-STD-883, Method 1010, Condition B, -55°C to +125°C, 10 Cycles
Burn-In	96 hours at +100°C
Final Electrical	100% at 25°C
External Visual	Internal Procedure



ORDERING INFORMATION

VPT15-	28	05	S	W
1	2	3	4	5

(1) Product Series	(2) Nominal Input Voltage		(3) Output Voltage		(4) Number of Outputs		(5) Package Option	
VPT15-	28	28 Volts	3R3 05 12 15	3.3 Volts 5 Volts 12 Volts 15 Volts	S	Single	None W	Standard Metal Epoxy Encapsulated

CONTACT INFORMATION

To request a quotation or place orders please contact your sales representative or the VPT Inc. Sales Department at:

Phone: (425) 353-3010
Fax: (425) 353-4030
E-mail: vptsales@vptpower.com

All information contained in this datasheet is believed to be accurate, however, no responsibility is assumed for possible errors or omissions. The products or specifications contained herein are subject to change without notice. VPT, its logo and tagline are registered trademarks in the U.S. Patent and Trademark Office.